

ESPRESSO COFFEE MACHINE

Use and maintenance manual. Instructions for the user.

English

Summary

1	Instructions.....	32	11	Cup heater (optional).....	44
1.1	Read carefully	32	12	Accessories.....	45
1.2	How to use this manual	32	12.1	Softener.....	45
1.3	General warnings	32	12.2	Cappuccino maker	46
1.4	Warranty	34	12.3	Milk foaming nozzle	47
1.5	Typographical conventions	34	12.4	Thermoreserve	47
2	Presentation	34	13	Suggestions on how to obtain a good cup of coffee	48
3	Warnings for the installer	35	14	List of hazards.....	49
3.1	Power	35	15	Checks and maintenance	50
3.2	Materials to be used	35	16	Cleaning	51
3.3	Hydraulic connections	35	17	Malfunctions and related solutions	53
3.4	Installation report	35			
3.5	Maintenance and repairs	35			
4	Description of the machine	36			
4.1	Description	36			
4.2	Technical data.....	37			
5	Preparing the machine	37			
6	Water renewal	37			
7	Starting the machine.....	38			
7.1	Electric heating.....	38			
7.2	Gas heating				
	(where a gas system is present).....	38			
7.3	Electric + gas heating				
	(if gas system is present)	39			
8	Preliminary operations	39			
8.1	Grinding and dosing	39			
8.2	Preparing the coffee	39			
8.3	Dispensing compartment light (optional) ...	40			
9	Preparing the coffee	40			
9.1	ALE version	40			
9.2	EMA version.....	40			
9.3	EPU version.....	40			
9.4	JUNIOR version	41			
9.5	EVD version	42			
10	Preparing hot beverages.....	43			
10.1	Manual dispensing of hot water	43			
10.2	Automatic hot water delivery	43			
10.3	Dispensing steam	43			

1 Instructions

1.1 Read carefully

Carefully read every part of this booklet before using the appliance.

The espresso coffee maker that you have purchased has been designed and manufactured with innovative methods and technologies which ensure long lasting quality and reliability.

This booklet will guide you in discovering the advantages of purchasing our product. You will find information on how to get the best of your appliance, how to always keep it efficient and what to do if you should have any problems.

Keep this booklet in a safe place. If you lose it, you can ask the manufacturer for another copy.

We take this opportunity to send you our best regards.

ENJOY YOUR READING... AND YOUR COFFEE

1.2 How to use this manual

The manufacturer reserves the right to make any improvements and/or modifications to the product. We guarantee that this booklet reflects the technical state of the appliance at the time it is marketed.

We take this opportunity to invite customers to make any proposals for improving the product or the manual.

1.3 General warnings

- After removing the packaging, check the condition of the appliance. If in doubt, do not use it but contact the retailer directly.
- The packaging material must not be left within the reach of children, since it is a potential source of danger. It is advisable to keep the packaging until after the warranty has expired.
- Before using the appliance, make sure that the mains voltage corresponds to the information on the data plate of the appliance.
- Installation must be done in accordance with the safety standards in force and by qualified and prepared personnel. Incorrect installation may be harmful to people, property or animals.
- This appliance is completely safe only if it is connected to an effective grounding system, carried out as required by current safety standards. The electric system must be equipped with a suitable differential circuit breaker. It is important to have these requirements checked. If in doubt, have the system carefully checked by qualified personnel. The manufacturer cannot be considered responsible for any damage caused by an inadequate electric system.
- Upon installation of the appliance, a main switch must be installed by qualified personnel, as required by current safety regulations, with an opening distance of the contacts equal to or greater than 3 mm.
- It is not advisable to use extensions or electrical adaptors with multiple outlets. If their use is indispensable, use only simple or multiple plug adaptors and extensions which are in accordance with the safety standards in force. Never exceed the power value in kW indicated on the simple adaptor and on the extensions and the maximum power value indicated on the adaptor.
- The espresso coffee appliance is intended for the preparation of hot beverages such as coffee, tea or warm milk. This appliance is to be used only for its intended purpose. Any other use is considered improper and therefore dangerous. The manufacturer cannot be held responsible for any damage caused by an incorrect and unreasonable use.

- When using the electrical appliance, several safety standards must be observed:
 - do not touch the appliance with wet or damp hands or feet;
 - do not use the appliance if barefooted;
 - do not use extensions in showering or bathing premises;
 - do not pull the power cord to disconnect the appliance;
 - do not leave the appliance exposed to atmospheric agents (rain, sun, etc...);
 - do not access the inside of the machine;
 - do not spill liquids on the machine;
 - do not allow the appliance to be used by children or incapacitated people.
- Make sure that the machine is used in a sufficiently lit, aerated, and hygienic premise.
- The access spaces to the machine and main switch must be left clear, in order to allow the user to intervene without any constrictions and be able to leave the area immediately in case of necessity.
- Do not spray water on the machine to clean it. Clean daily following the instructions given in this manual.
- Before any maintenance, disconnect the appliance from the electrical mains through the main switch.
- In case of breakdowns or poor functioning, turn off the appliance, do not attempt any repairs; call for specialised technical service.
- Any repairs must be done only by the manufacturer or an authorised service centre, using original spare parts only. If this standard is not observed, the safety of the appliance is compromised and the warranty may be void.
- There is a lithium battery button inside the device to prevent programming data loss..
- The power cord of the appliance must not be replaced by the user. If the cord is damaged, turn the appliance off and contact professionally qualified personnel only.
- If you should decide not to use the appliance any longer, unplug it and have it drained of water by qualified personnel.
- To guarantee that the machine is efficient and works properly, it is essential to follow the manufacturer instructions, having periodical maintenance and a check of all the safety devices done by qualified personnel.
- Do not expose your hands or other body parts to the coffee, steam, or hot water spouts. The steam and water that exit the nozzles can cause burns.
- When functioning, the filter holder, the steam and water spouts become overheated and are to be handled with caution only in the indicated parts.
- Cups must be placed on the special cup-heating surface only after having been thoroughly dried.
- The dishes belonging to the machine itself are to be placed on the cup-heater surface. It is incorrect to place any other object on this surface.
- The appliance must not be used by people (including children) with reduced physical, sensorial or mental capacities, or by people without experience or knowledge, unless they can be supervised or receive instructions for appliance use from a person responsible for their safety.
- Children must be supervised, to make sure they do not play with the appliance.
- The coffee machine must be used at a temperature between 5°C and 40°C.
- Any unauthorised tampering with any parts of the machine renders any guarantee null and void.
- **WARNING:** consuming beverages that have been prepared in this espresso machine will expose you to lead, a chemical known to the State of California to cause birth defects or other reproductive harm.

1.4 Warranty

15 months on all components, except for electrical and electronic components and expendable pieces.

1.5 Typographical conventions



This symbol indicates that you must strictly follow the instructions it refers to, in order to avoid damage to the appliance or injury.



This symbol provides additional information on the operation of the machine and its components.

2 Presentation

This product has been manufactured in compliance with the regulations for foodstuff machinery according to par. 2.1 of Directive 2006/42/EC.

The espresso coffee maker is strictly for professional use only. It is designed for the preparation of hot drinks such as tea, cappuccinos, long, short and espresso coffee, etc. If the model has two or more groups, it can be used by two or more people simultaneously. This characteristic, together with the fact that the machine is able to deliver drinks continuously without any problems, guarantees its intensive use.

The instructions for a proper use of the machine are provided below.



The user must be sufficiently informed to operate the appliance correctly. It is recommended not to carry out any operations on the machine which may modify or alter its operation. WHEN THE MACHINE IS OPERATING, THE BOILER CONTAINS STEAM AND HOT WATER UNDER PRESSURE.



The machine's installation and maintenance operations can only be carried out by qualified technical personnel. Qualification can be provided by the builder through participation in specific training courses.

3 Warnings for the installer

3.1 Power

The water supply of the appliance must be carried out with water which is suitable for human consumption, in compliance with the regulations in force in the place of installation. The owner / manager of the system must confirm to the installer that the water meets the above listed requirements.

3.2 Materials to be used

During the installation of the appliance the components and materials that were provided with the appliance are to be used. Should the use of other components be necessary, the installer must verify their suitability to be used in contact with water used for human consumption.

3.3 Hydraulic connections

The installer must carry out the hydraulic connections in accordance with the hygiene norms and the hydraulic safety norms for environmental protection in force in the place of installation.

3.4 Installation report

When installation is complete, the appliance has to be started, brought to the nominal working condition and left for 30 minutes in the "ready to operate" condition.

Afterwards, the appliance has to be turned off and emptied of the first water introduced in the whole hydraulic circuit, to eliminate possible initial impurities.

Then the appliance must be once again loaded and brought to the nominal working conditions.

After having reached the "ready to operate" condition, the following deliveries have to be performed:

- For each coffee unit, carry out a continuous delivery, in order to release at least 0.5 liters of the coffee circuit. In the case of several dispensing points matched with the same exchanger/coffee boiler, divide the volume on the base of the number of the dispensing points;
- Release the whole volume of hot water inside the boiler (3 litres for 1GR, 6 litres for 2GR, 8 litres for 3GR), by performing a continuous delivery from the appropriate nozzle. In the case of several dispensing points, divide the volume on the base of the number of the dispensing points;
- Continuously release steam for at least 1 minute for each steam dispensing point.

3.5 Maintenance and repairs

After a maintenance and/or repair intervention, the components used must ensure that the hygiene and safety requirements initially foreseen for the appliance are still met. These are met by using original spare parts only.

After a repair or a substitution of components related to parts in direct contact with water and food, a washing procedure has to be carried out, as in the case of first installation.

4 Description of the machine

4.1 Description

ALE

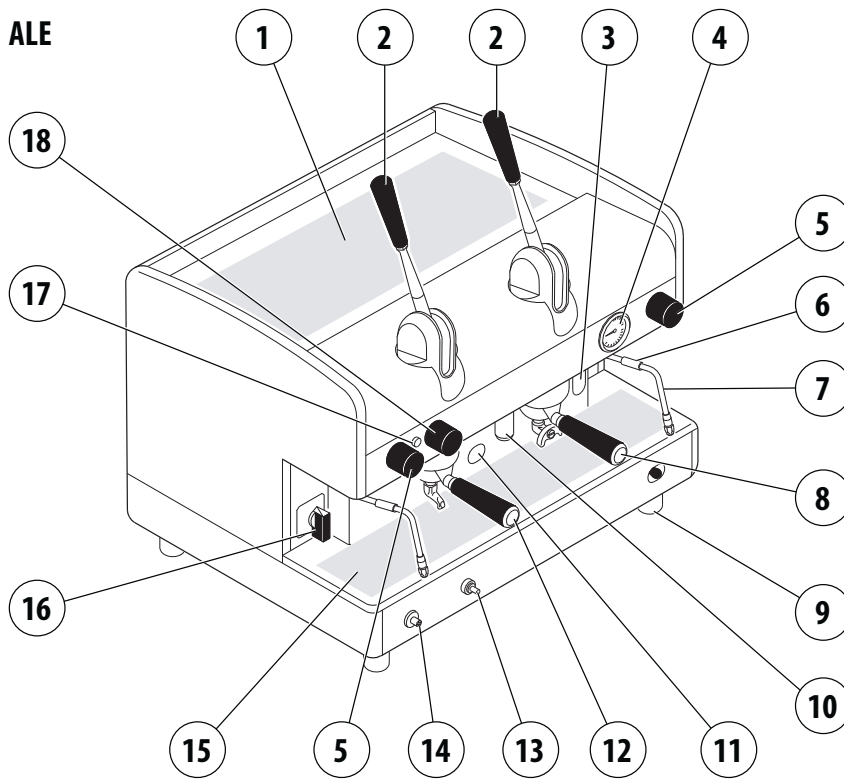

1. Cup heater surface.
2. Lever groups.
3. Optical boiler water level (**)
4. Pressure gauge.
5. Steam knob.
6. Burn protection.
7. Steam nozzle.
8. 2-Cup filter holder.
9. Adjustable foot.
10. Hot water nozzle.
11. Gas burner viewing window. (*)
12. 1-Cup filter holder.
13. Gas safety. (*)
14. Gas lighting button. (*)
15. Cup-rest grid.

EMA-EPU-EVD

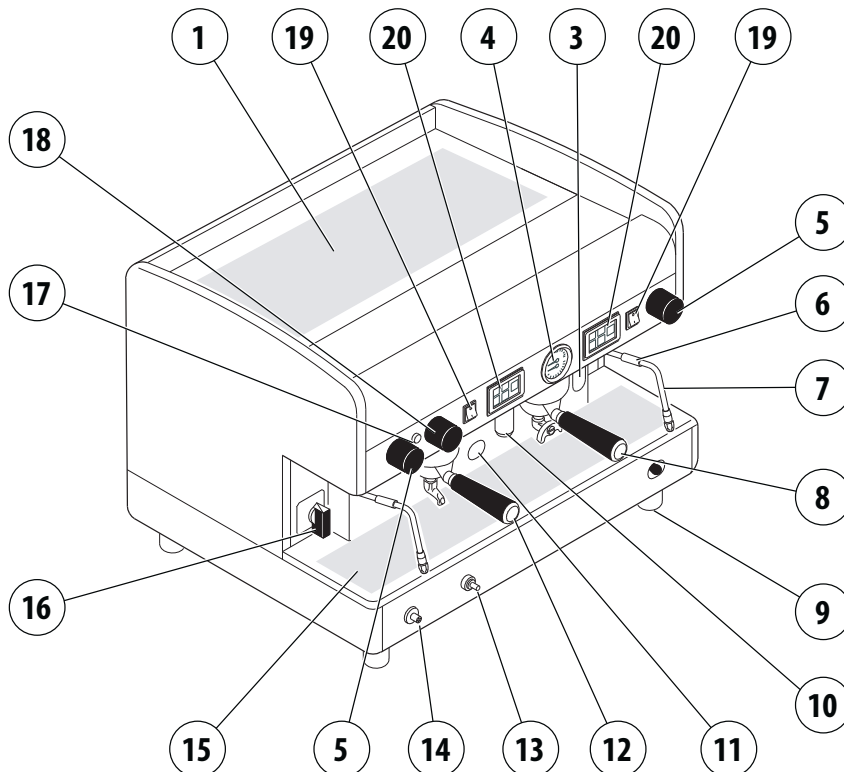

1. Cup heater surface.
2. Lever groups.
3. Optical boiler water level (**)
4. Pressure gauge.
5. Steam knob.
6. Burn protection.
7. Steam nozzle.
8. 2-Cup filter holder.
9. Adjustable foot.
10. Hot water nozzle.
11. Gas burner viewing window. (*)
12. 1-Cup filter holder.
13. Gas safety. (*)
14. Gas lighting button. (*)
15. Cup-rest grid.
16. Start-up switch.
17. Warning lights.
18. Hot water knob.
19. Manual delivery switches.
20. Push-button panels.

(*) *Optional device.*

(**) *In some versions the optical level is replaced by a green light.*

4.2 Technical data

The nameplate of the machine is fixed on the base of the frame under the drain pan.

The data of the appliance can be seen also on the label located on the package of the machine.

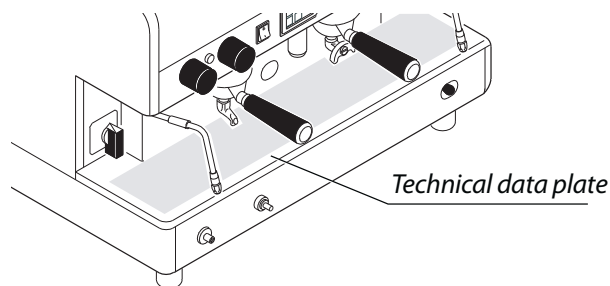

		JUN	1GR	COMPATTA	2GR	3GR	4GR
Power supply voltage	V	120-230 240	120-230 240-400	120-230 240-400	120-230 240-400	120-230 240-400	230-240 400
Absorbed power	W	2.300	2.300 3.000	3.000 3.000	3.700 3.900	5.300	6.300
Steam boiler capacity	L / gal UK	3,5 / 0.92	5 / 1.32	7 / 1.85	12 / 3.17	17 / 4.49	22 / 5.81
Safety valve calibration (bar)	bar / psi	1.9 / 27.6					
Boiler operating pressure	bar / psi	0.8-1.4 / 11.6-20.3					
Feedwater pressure	bar / psi	1.5-5 (MAX) / 21.8-72.5 (MAX)					
Coffee dispensing pressure	bar / psi	8-9 / 116-130.5					
Operating conditions	°C / °F	5-40 / 41-104					

Technical data table

5 Preparing the machine

The preparation of the machine and the installation operations must be carried out by qualified personnel only. The installer must strictly follow the indications provided in chapter "Warnings for the Installer".

i Using the machine without all the installation operations having been carried out by technical personnel could damage it seriously.

6 Water renewal

In case of breaks longer than 1 week, it is necessary to perform the changing of the 100% of the water contained in the hydraulic circuits of the machine, by using the appropriate dispensing points, as described in the paragraph "Installation report".

7 Starting the machine

7.1 Electric heating

Before starting the machine, make sure that the level of water in the boiler is higher than the minimum level on the level-check window (1).

In some versions the optical level is replaced by a green light (3): the light indicates the proper water level of the boiler, slow flashes indicate the phase of water loading.

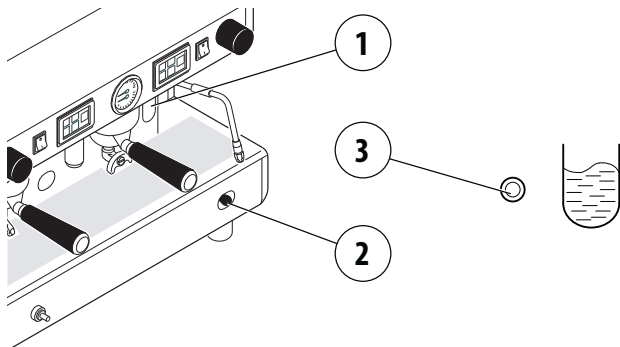

If there is no water (first installation or after boiler maintenance), it is necessary to fill the boiler in advance, so as to prevent overheating of the heating element.

Proceed as follows :

Switch

- Open the water tap of the water mains and of the softener;
- Using manual fill (2) fill the boiler with water until the optimal level is restored;
- Turn the switch to position "1" and wait for the machine to warm up completely.

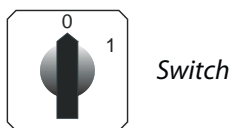

Power switch

- Open the water tap of the water mains and of the softener.
- Turn the switch to position "1" (electrical power supplied to the pump for automatic boiler replenishment and machine services) and wait for the boiler to be automatically filled with water;
- Turn the switch to position "2" (full electrical power supplied, including the heating element in the boiler) and wait for the machine to warm up completely.



7.2 Gas heating (where a gas system is present)

- Turn the main switch (A) to position 1;
- open the gas valve (B) on the mains;
- hold down button (C) and press the on button (D) at the same time. Once the flame ignites, hold down knob (C) for a few seconds to allow proper activation of the thermocouple;
- then, confirm that the flame has ignited by looking through the window (E);
- wait for the operating pressure indicated on the pressure gauge to reach a working value of 1-1.2 bar;

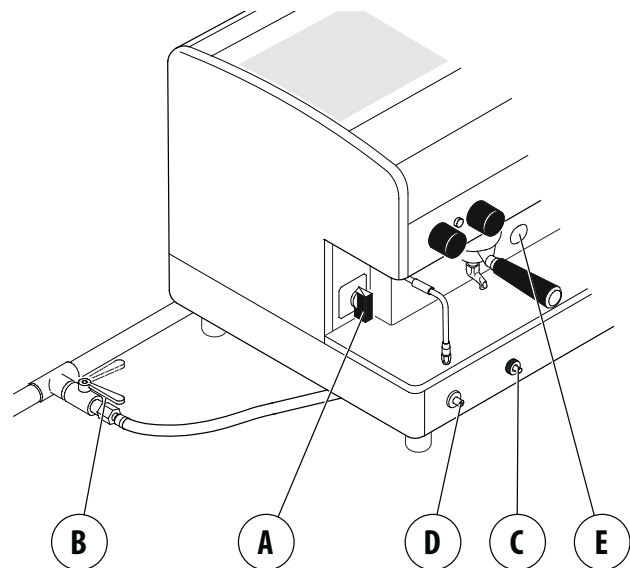

7.3 Electric + gas heating (if gas system is present)

- Proceed as indicated in paragraph 7.2 "Gas heating";
- after confirming that the flame has ignited, turn the main switch (A) to position 2. In this way the boiler heating element is powered and operating pressure will be reached more quickly;
- wait for the operating pressure indicated on the pressure gauge to reach the working value of 1-1.2 bar;



The connection and tune up of the gas system has to be performed by technical staff. In case of gas-related changes or malfunction, contact the technical support.



- For reasons of safety, gas heating must be shut down during long periods of disuse of the machine (during the night or when the establishment is closed).
- It is not advisable to put cloths or other objects on the cup heater, as this obstructs normal air flow.
- Do not operate the gas burners when the boiler is empty. During the machine's warm-up phase (roughly 20 minutes), the negative pressure valve will release steam for a few seconds until the valve itself closes



During the machine's warm-up phase (roughly 20 minutes), the negative pressure valve will release steam for a few seconds until the valve itself closes.

8 Preliminary operations

8.1 Grinding and dosing

It is important to have a dosing-grinding device next to the machine with which to grind the coffee to use daily.

The grinding and the dosing of the coffee must be done according to that indicated by the manufacturer of the dosing-grinding device. The following points are also to be kept in mind:

- to obtain a good espresso it is recommended not to keep large stocks of coffee grains. Observe the expiry date indicated by the producer.
- never grind large volumes of coffee, it is advisable would be to have the quantity contained in the dosing device and use it if possible by the end of the day.
- if possible, never buy coffee that is already ground as it expires quickly. if necessary, to buy it in small vacuum-sealed packages.

8.2 Preparing the coffee

- Fill the filter with a dose of ground coffee (circa 6-7 gr.) and press it with the press;
- hook the filter-holder to the unit without closing it too tightly in order to avoid excessive wear of the gasket;
- for the same reason it is recommended to clean the edge of the filter before attaching the filter holder to the dispensing unit;
- follow the procedures specified by the manufacturer of the grinder.

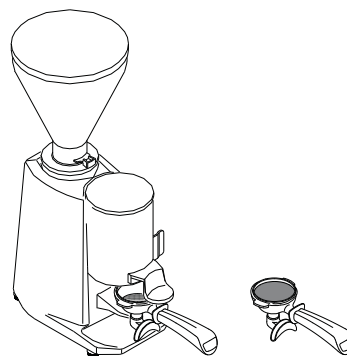

8.3 Dispensing compartment light (optional)

To turn on and turn off the work compartment lighting, press switch, which is located under the command facade on the left side.

- **Before using the machine, run deliveries dry with the filter holder attached for a few seconds to release any air which may be in the circuit, so that the delivery groups are completely heated;**
- **before using the machine, dispense a few servings of coffee to test the grinding and to check the operating pressure of the machine;**
- **during the coffee brewing, do not remove the filter holder from the group.**

9.2 EMA version

- Put the coffee cup under the dispensing spout;
- raise the lever: the coffee starts pouring and can be stopped bend the lever, when the desired amount of coffee has been delivered.

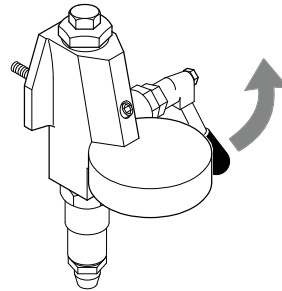

9 Preparing the coffee

9.1 ALE version

- Place the coffee cup under the dispensing spout;
- pull the lever all the way down;
- wait for a few seconds (3-5 seconds);
- raise the lever until you meet some resistance, then release it;
- wait until coffee delivery is complete.

- **Never perform the above actions without coffee in the filter or without the filter holder attached to the delivery group. The rapid upward movement of the lever may cause damage to the appliance, individuals or property. Delivery time deepens on grinding and the amount of coffee in the filter holder.**

9.3 EPU version

- Place the coffee cup under the dispensing spout;
- press the desired delivery switch: you will have the delivery which can be stopped by means of the same switch once the desired amount of coffee in the cup is obtained.

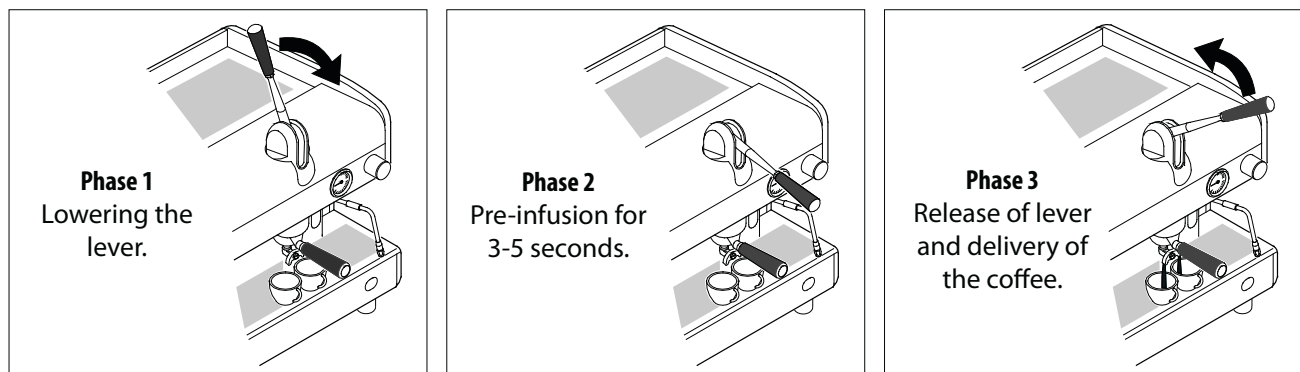
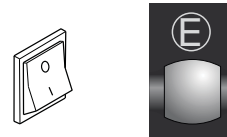

9.4 JUNIOR version

Programming

- Place the programming lever **(1)** in the ON position. It is located under the front right-hand panel of the body;
- place the coffee cup under the dispensing spout;
- press the PROG/STOP key for at least 5 seconds until all dose key LED are on;
- press the desired dose button;
- to confirm the dose press the dose key or the PROG/STOP key again;
- repeat this operation for the other dose buttons;
- programming will be terminated automatically after a few seconds.
- upon completion of programming, place the programming lever **(1)** back in the OFF position.



Coffee delivery

- Place the coffee cup under the dispensing spout;
- press the desired dose key: wait for coffee to be delivered (LED comes on);
- to stop delivery of coffee in advance, press the delivery key again or press the key STOP;
- in the event of anomalies or if the push button panel is locked, use the manual switch. **(2)**.

● The programming of every dose must be done with ground coffee and not with previously used grounds.

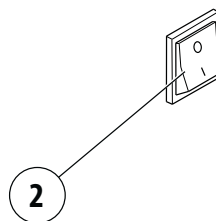
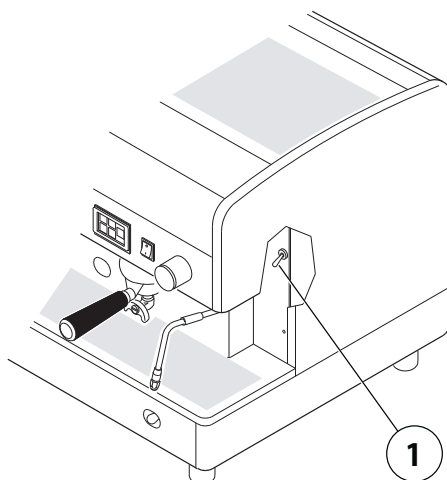

9.5 EVD version

Programming

Always program the right push-button panel first, and, if necessary, the others subsequently.

- Place the programming lever **ON** la levetta di programmazione (1) posta sotto il pannello frontale destro della carrozzeria;
- place the coffee cup under the dispensing spout;
- press the PROG/STOP button (2) of the first right-hand push-button panel; all the dose button LEDs will come on;
- press the desired dose button (3)
- when the desired dose has been attained, confirm by pressing the PROG/STOP button (2);
- repeat this operation for the other dose buttons;
- when finished programming, return the programming lever (1) to the **OFF** position.

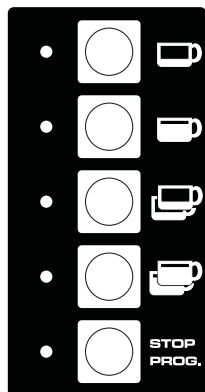
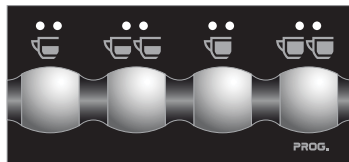
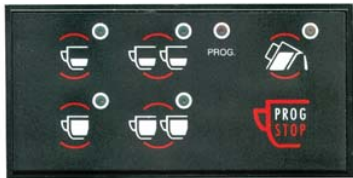

In some models, the programming lever has been eliminated; to access the programming, it is enough to press the PROG/STOP key for at least 5 seconds with all push button panel LED coming on. To confirm the dose press the PROG/STOP key or the selected dose key again.

In other models, to access programming it is necessary to use a special key switch.

To exit programming it is sufficient to wait a few seconds.

- **By operating on the right push-button panel, the other push button panels are programmed automatically.**
- **Programming of each dose must be carried out with ground coffee and not with previously used grounds.**

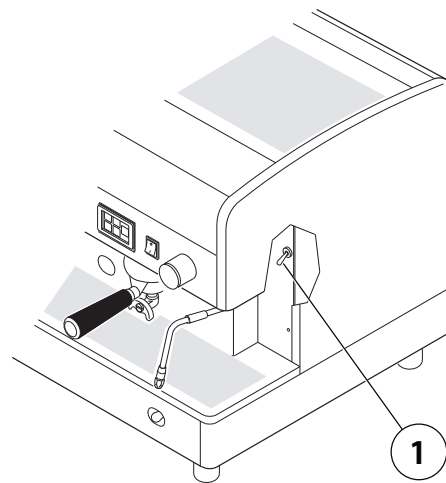

Coffee delivery

- Place the coffee cup under the dispensing spout;
- press the desired dose key and wait for coffee to be delivered (LED comes on).

To stop dispensing ahead of time, press the STOP/PROG button again or the button selected again. If the push button panel is locked, use the manual Coffee Delivery button.

10 Preparing hot beverages

10.1 Manual dispensing of hot water

- Place the jug under the hot water nozzle (2);
- turn the tap knob (1): counterclockwise: the hot water coming out of the nozzle (2) will be proportional to the opening of the tap;
- to interrupt the hot water dispensing turn the knob counter-clockwise (1).

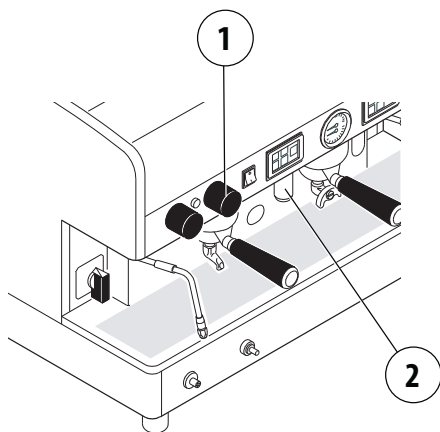

Dispensing hot water

- put the cup under the hot water spout (2);
- press the hot water key (3): wait for the delivery of water;
- to stop delivery in advance, press the hot water delivery key (3) again or press the STOP key.



! Do not touch the hot water nozzle: contact with the nozzle or the steam may be harmful to people, animals or property.

10.2 Automatic hot water delivery

Programming

- Place the programming lever (4) in the ON position. It is located under the front right-hand panel of the body (in some versions to start operating it will be sufficient to maintain the PROG/STOP (5) key pressed for 5 seconds or to turn the programming key);
- put the cup under the hot water spout (2);
- press the PROG/STOP key (5) and all dose key LED will come on;
- press the hot water delivery key (3);
- when the desired dose has been attained, confirm by pressing the PROG/STOP key (5);
- upon completion of programming, place the programming lever (4) back in the OFF position.

10.3 Dispensing steam

- Immerge the steam-dispensing nozzle (7) in the liquid to heat;
- turn the tap knob (6) counterclockwise: the steam coming out of the nozzle (7) will be proportional to the opening of the tap;
- to interrupt the steam dispensing turn the knob counter-clockwise (6).

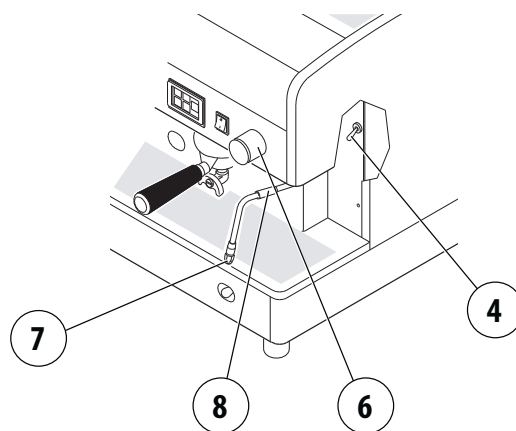

For optimal foaming, it is recommended to observe the following simple rules:

- heat only the amount of milk you intend to use; once heated, it will have to be completely poured from the jug and not heated again;
- the milk to be foamed must have a starting temperature of 4°C;



The use of the steam dispensing point (steam nozzle) must always be preceded by the performance of the condensation draining operation for at least 2 seconds.



Leave the steam nozzle immersed in the milk only for the time required for heating. Do not open the steam tap with the steam nozzle immersed in milk while the machine is off.



Carefully operate the steam nozzle using the anti-burn rubber washer (5): contact with the nozzle or the steam may be harmful to people, animals or property.



To keep the steam nozzle tips in perfect working order, it is advisable to carry out a brief dry delivery after each use. Keep the tips clean at all times using a cloth dampened in lukewarm water. Handle the nozzle with utmost caution due to the hazard resulting from the presence of high-temperature steam.

11 Cup heater (optional)

The cup heating device is for heating cups before they are used.

- place the cups on the upper surface (1) of the coffee machine;
- start the electric heating element with the switch (2).

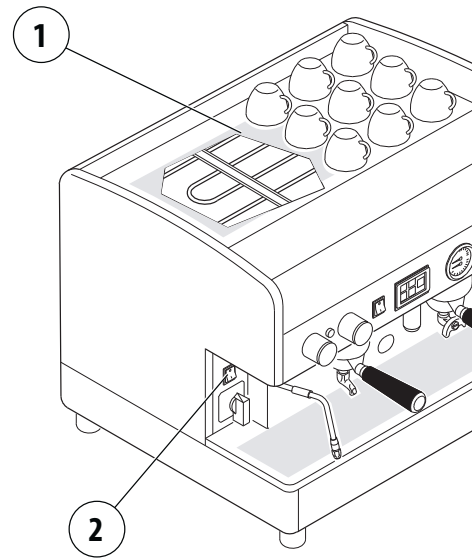

For safety reasons we advise against putting cloths or other objects on the upper surface (1) of the machine as they could obstruct normal air circulation.

12 Accessories

12.1 Softener

Mains water contains insoluble salts, which cause the build-up of lime scale deposits in the boiler and in other parts of the machine. The softener makes it possible to eliminate or substantially reduce the presence of these mineral salts. The resin softener has the property of retaining the calcium contained in the water. For this reason, the resins become saturated after a certain period and must be regenerated with coarse kitchen salt (NaCl, sodium chloride) or special water softening salt. It is very important to regenerate the softener within the established times. The regeneration is to be done regularly every 15 days. However, in locations with very hard water, it will be necessary to regenerate more frequently. The same rule can be applied to places where there is a large consumption of hot water for tea or other uses.

Softener regeneration

Proceed as follows:

- move levers **(B)** and **(E)** from left to right;
- remove the lid by loosening the knob **(A)**;
- release enough water through the pipe **(C)** to make room for the amount of salt as required depending on the model (see table);
- clean any salt or resin residue from the gasket located on the lid;
- put the cover back in place by screwing the knob **(A)** down securely and move the lever **(B)** back from right to left;
- let the salt water drain from the little hose **(D)** until the water is no longer salty (about 30-60 minutes). The salt allows the accumulated mineral salts to be released;
- switch the lever **(E)** from right to left back to its initial position.

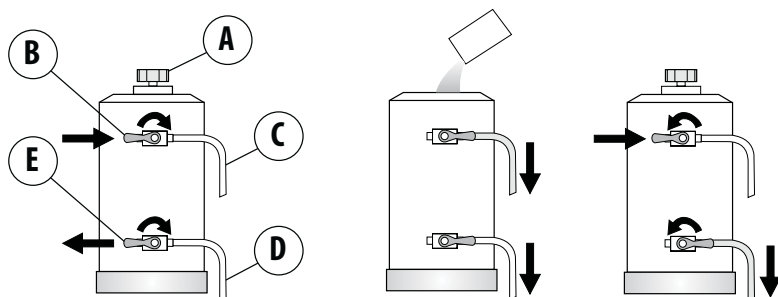

The build-up of lime scale deposits in the hydraulic circuit and boiler inhibits thermal exchange, thus compromising proper operation of the machine. Heavy incrustations in the boiler may cause long machine shutdowns and in any case invalidate any guarantee, because this symptom indicates that regeneration has been neglected.

In order to keep the softener and hence the machine in perfect operating condition, it is necessary to perform regeneration periodically based on the use of the softener and the hardness of the water that is used. The table below shows the quantity of softened water based on the hardness of the water in the various units of measure:

- °f French degree
- °d: German degree = 1.8 °f
- mg CaCO₃

For further information on installation, start-up and regeneration of the softener, refer to the relative instruction manual.

Amount of softened water based on hardness

°f	30	40	60	80	salt
°d	16,5	22	33	44	
mg CaCO ₃	30	40	60	80	
8 liters	1000 lt	900 lt	700 lt	500 lt	1.0 kg
12 liters	1500 lt	1350 lt	1050 lt	750 lt	1.5 kg
16 liters	2100 lt	1800 lt	1400 lt	1000 lt	2.0 kg

Softener model	Amount of salt
8 liters	1.0 kg
12 liters	1.5 kg
16 liters	2.0 kg

12.2 Cappuccino maker

- Put the suction tube inside the milk;
- place the jug under the spout of the cappuccino maker;
- open the steam tap, when the desired amount is reached close the steam tap;
- pour the milk into the cups with the coffee.

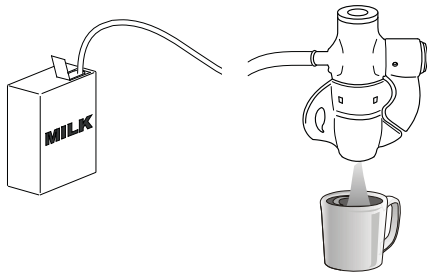

i To obtain the dispensing of warm milk without foam, lift the tab (Z) upwards. For better results, we suggest not to dispense directly into the coffee cup, but into a jug or pot, and to then pour the foamed milk on the coffee. Be sure the cappuccino maker is kept clean as described in the chapter "Cleaning".

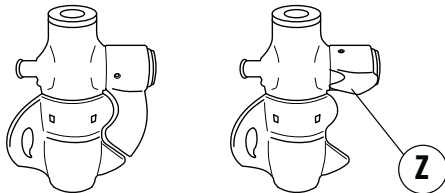

Cleaning

Use special care in cleaning the cappuccino maker, following the procedures indicated below:

- perform a first washing by immersing the suction tube in water and run a delivery for a few seconds;
- turn the rotating body (X) 90° to position B (closure of milk outlet duct);
- holding the milk suction tube in the air, dispense steam (cappuccino maker dry run);
- wait about 20 seconds to allow for internal cleaning and sterilisation of the cappuccino maker;
- close the steam and put the rotating body back in position A;
- if the air intake hole (Y) is blocked, clear it gently with a pin.

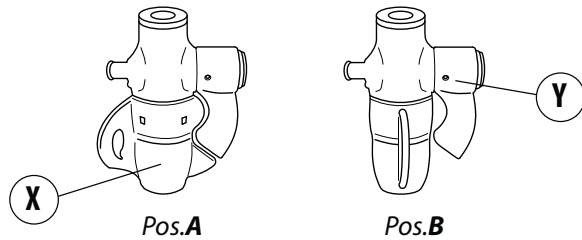

! It is advisable to clean the cappuccino maker after each period of continued use so as to avoid malfunctions and to ensure a high rate of hygiene in the system.

12.3 Milk foaming nozzle

- Insert the nozzle **(4)** in the milk so that the sprayer is completely covered;
- turn the steam tap **(2)** counter-clockwise;
- wait for the milk to heat and foam;
- upon reaching the desired temperature and foaming, turn the steam tap **(2)** clockwise;

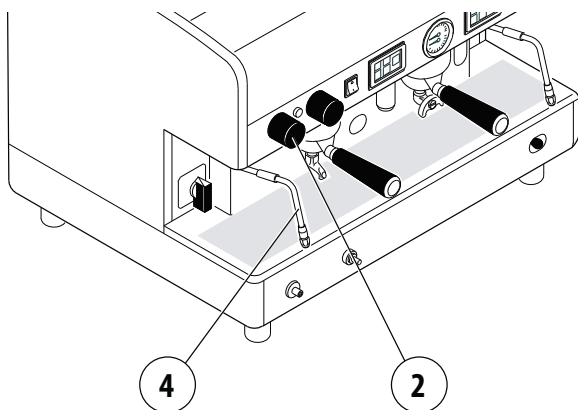

- To adjust the foaming of the milk: unscrew the cap **(B)** of the regulator and use a screwdriver on the screw **(C)**. To increase foaming, turn counterclockwise; to reduce foaming, turn clockwise.

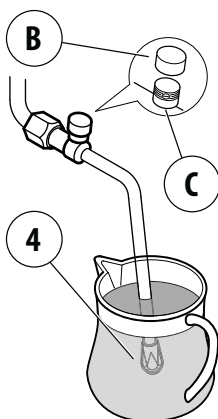

12.4 Thermoreserve

This is composed of a recipient where a substantial amount of coffee is produced (2.5 litres) which is stored in reserve when there is high demand for this beverage (breakfasts, conferences, etc.).

Preparation

- Raise the lid **(1)** pulling the knob to the left and raising the lever;
- place the ground coffee (about 130 gr.) into the specific filter **(2)** and close it triggering the knob in safety position;
- open the water tap **(3)** by turning it counter-clockwise. Upon reaching the desired amount (maximum capacity 2.5 litres) close the tap;
- when the operation is complete, residual pressure must be discharged with the discharge valve **(5)** located under the heat storage group.

Dispensing

Coffee is drawn from the container by using the lever of the dispenser **(4)** located in the middle of the lower part. The remaining coffee can be heated by means of a steam tap **(6)** located on the right hand side.

To keep the milk foaming device in perfect working order, it is advisable to carry out a delivery dry run after each use.

Keep the ends of the of the nozzle clean at all times by means of a cloth dampened in lukewarm water. Use the utmost caution with the milk foaming nozzle, as high-temperature steam is present.

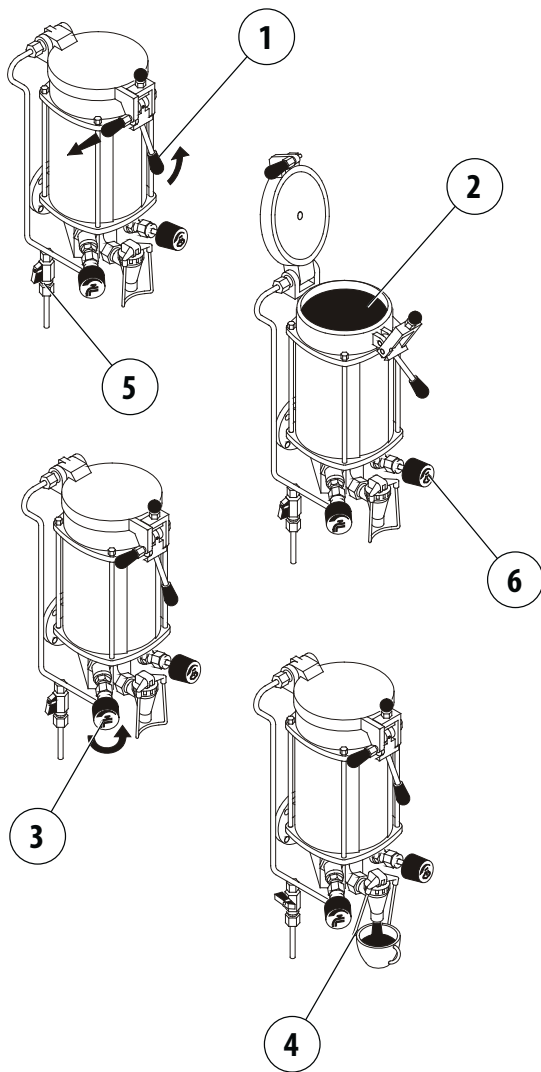

13 Suggestions on how to obtain a good cup of coffee

To obtain high-quality coffee, it is important for the hardness of the water used to not exceed 4-5 °f (French degrees). If the water hardness exceeds these values, it is advisable to use a water softener.

Avoid using a water softener if the water hardness is less than 4 °f.

If the taste of chlorine in the water is particularly strong, a special filter should be installed.

It is not advisable to keep large supplies of coffee beans. Never grind large amounts of coffee. Use the amount the doser holds and, if possible, use it by the end of the day. Never purchase ground coffee, as it expires quickly.

After the machine has not been used for a certain period of time (2-3 hours) carry out a few dry runs.

Make sure to carry out regular cleaning and maintenance.

If the type of coffee is changed, we recommend you to contact the Technical Support Service for the water temperature adjustment.

Adjust the grinding of the coffee according to the degree of humidity in the environment.

- **Always open the bleed valve (5) before opening the lid. Failure to do so may cause serious harm to property, individuals or animals.**

14 List of hazards

This chapter describes possible hazards for the user if the specific safety standards (described in this manual) are not followed.

The appliance must be connected to an efficient grounding system

If this is not done, the appliance can be a source of dangerous electrical shocks as it is no longer able to discharge electricity to earth.

Do not use running water for washing

The use of pressurized water directly on the machine can seriously damage the electrical equipment. Never use water jets to wash any part of the appliance.

Be careful of the steam and hot water nozzles

During use, the steam and hot water nozzles become very hot and are thus a potential source of danger.

Handle these parts carefully. Never direct steam or hot water jets directly on the body.

Do not work on the machine when it is supplied with electrical power

Before carrying out any maintenance or repair work on the machine you must turn it off using the main switch or, better yet, disconnecting the mains connection terminals. Never remove any body panel when the machine is supplied with electrical power.

If you should decide not to use the appliance, it is necessary to shut it down by disconnecting the power supply cable from the electrical mains, closing the inflow of water from the hydraulic mains and emptying the hydraulic system.

For the operations of disconnection from the electrical and hydraulic mains and of release of the water, qualified personnel has to be contacted.

Never work on the hydraulic system before having emptied it

All work regarding the hydraulic system and the related boiler is to be avoided when there is still water and pressure in the system. Thus you must empty it beforehand by closing the mains tap and dry-running the delivery group for a short time.

Switch off the machine and turn on all the steam and water taps. When the pressure is zero, empty the boiler completely by unscrewing the special pipe fitting located on the lower part of boiler.

If the above procedure is not carried out correctly, opening any part of the hydraulic system can cause a sudden outburst of superheated water under pressure.

Lever machines

Never lower the lever if there is no coffee in the filter, or if the filter holder is not installed on the group: the sudden upwards movement of the lever may damage the appliance and injure individuals.

Gas machines

Periodically check for gas leaks in the system by applying a soapy solution to the ducts.

For safety reasons, close the gas heating system when the machine is not in use (at night or during hours of closure).

Use of the appliance

This espresso coffee machine is an appliance for professional use only. Any other type of use is considered incorrect and therefore dangerous. Never allow children or people not familiar with it to use the machine.

Non-observance of the above-described standards can cause serious harm to people, property or animals.

Never operate the electronic apparatus when the appliance is supplied with electrical power.

Shut down the appliance completely by disconnecting it from the power outlet before carrying out any operation.

15 Checks and maintenance

To ensure perfect safety and efficiency of the machine over time, it is necessary to carry out maintenance. In particular, it is advisable to ask Technical Service to carry out an overall check of the machine at least once a year.

Intervention	Weekly	Monthly
GAUGE Keep the boiler pressure between 0.8 and 1.4 bar.	X	
GAUGE Periodically check water pressure during coffee delivery: check the pressure indicated on the gauge, which must be between 8 and 9 bar inclusive.		X
FILTERS and FILTER HOLDERS Check the condition of the filters. Check for any damage on the edge of the filters and check whether any coffee grounds settle in the coffee cup.		X
GRINDER-DOSER Check the dose of ground coffee (between 6 and 7 gr. per stroke) and check the degree of grinding. The grinders must always have sharp cutting edges. Their deterioration is indicated by the presence of too much powder in the grounds. You should replace the flat grinders after every 400/500 kg of coffee. For conical grinders, replace every 800/900 kg.		X
SOFTENER The build-up of lime scale deposits in the hydraulic circuit of the machine indicates that regeneration has been neglected. Use care in areas where the water is very hard. It will be necessary to regenerate at more frequent intervals, likewise if there is high consumption of hot water for tea and so forth.		X



If the problem cannot be resolved, turn the machine off and call for Technical Assistance. Do not attempt any sort of repairs.

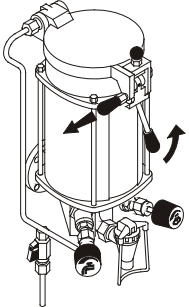

The descaling of the machine must be carried out by professional technicians to ensure that such operation does not lead to release of hazardous materials for food use.

Cleaning	Daily	Weekly
<p>GRINDER-DOSER</p> <p>Every week clean the bell jar and the dosing device with a cloth soaked in lukewarm water, both inside and out, then dry it.</p>		X
<p>HEATED STORAGE</p> <p>Once the coffee in the heated storage container is finished, clean it as follows.</p> <ol style="list-style-type: none"> 1. remove the filter using a cloth and avoiding direct contact with the hot parts; 2. empty the coffee grounds out of the filter and wash it with lukewarm water; 3. remove the plastic funnel and wash it with lukewarm water; 4. clean the container with a damp cloth and dry it; put the filter and funnel back in place. 		X

- When cleaning, always use cloths that are completely clean and hygienic.
- To guarantee the correct operation and hygiene of the hot beverages dispenser, it is necessary to use the cleaning methods and products suitable for this purpose.
- Do not use a solid filter to clean the machines with a lever group (ALE).
- Do not immerse the machine into water.
- Never use alkaline detergents, solvents, alcohol or aggressive substances.
- The descaling of the machine has to be performed by specialized technicians, by disassembling the components with deposits, so that no descaling debris is put into circulation. The used products/detergents have to be suitable for this purpose and must not corrode the materials of the hydraulic circuits.

17 Malfunctions and related solutions

Problem	Cause	Solution
MACHINE LACKING POWER	The machine is off.	Turn on the machine.
NO WATER IN BOILER	The water supply tap is closed.	Open the water supply tap.
TOO MUCH WATER IN BOILER	Malfunction of the electrical system or hydraulic system.	Call for Technical Assistance.
STEAM DOES NOT COME OUT OF STEAM SPOUTS AND AUTOSTEAMER	<ul style="list-style-type: none"> The nozzle sprayer is clogged. The machine is off. 	<ul style="list-style-type: none"> Clean the steam nozzle sprayer. Turn on the machine.
STEAM MIXED WITH WATER COMES OUT OF THE NOZZLES AND THE AUTOSTEAMER	Malfunction of the electrical system or hydraulic system.	Call for Technical Assistance.
NO DISPENSING	The water supply tap is closed.	Open the water supply tap.
WATER LEAKS FROM THE MACHINE	<ul style="list-style-type: none"> The pad does not drain. The drain pipe is broken or detached or the water flow is obstructed. 	<ul style="list-style-type: none"> Check the sewer drain. Check and restore the connection of the drain pipe to the pad.
COFFEE IS TOO HOT or TOO COLD	Malfunction of the electrical system or hydraulic system.	Call for Technical Assistance.
COFFEE IS BEING DISPENSED TOO QUICKLY	Coffee is ground too coarsely	Adjust the grinding of the coffee.
COFFEE IS BEING DISPENSED TOO SLOWLY	Coffee is ground too finely.	Adjust the grinding of the coffee.
WET COFFEE GROUNDS	<ul style="list-style-type: none"> Dispensing group is dirty. The dispensing unit is too cold Coffee is ground too finely. Coffee is too old 	<ul style="list-style-type: none"> Wash the group with the blind filter Wait for the group to heat up completely Adjust the grinding of the coffee. Replace with fresh coffee
THE PRESSURE GAUGE INDICATES AN UNACCEPTABLE PRESSURE	Hydraulic system failure	Call for Technical Assistance.
THERE ARE GROUNDS IN THE CUP	<ul style="list-style-type: none"> The filter holder is dirty. The filter holes are worn. The coffee is not ground evenly. 	<ul style="list-style-type: none"> Clean the filter holder. Replace the filter. Adjust the grinding suitably.

Problem	Cause	Solution
THE CUP IS DIRTY WITH COFFEE SPURTS	<ul style="list-style-type: none"> Coffee is ground too coarsely The filter edge is damaged 	<ul style="list-style-type: none"> Adjust the grinding of the coffee. Replace the filter.
<ul style="list-style-type: none"> ALL THE LED'S OF ALL THE PUSH BUTTON PANELS FLASH (EVD) THE TIME-OUT LED IS ON (EPU) 	<p>After a few minutes, the automatic filling of the water stops.</p> <ul style="list-style-type: none"> The device is in time-out. No water in the mains 	<ul style="list-style-type: none"> Turn the machine off and then back on. Open the water supply tap.
<ul style="list-style-type: none"> COFFEE DISPENSING IS NOT CONFORMANT THE COFFEE DOSE IS NOT MET THE LED OF THE DOSE BUTTON FLASHES 	Coffee is ground too finely.	Adjust the grinding of the coffee.
COFFEE DISPENSING OCCURS ONLY USING THE MANUAL BUTTON	Electronic system failure	Call for Technical Assistance.
SHUTDOWN OF THE ELECTRONIC SYSTEM	Malfunction of the electrical system or hydraulic system.	Call for Technical Assistance.
THE PUMP LEAKS WATER	Pump malfunction.	Call for Technical Assistance.
THE MOTOR STOPS SUDDENLY OR THE THERMAL PROTECTOR INTERVENES DUE TO OVERLOAD	Pump malfunction.	Call for Technical Assistance.
THE PUMP FUNCTIONS BELOW NOMINAL CAPACITY	Pump malfunction.	Call for Technical Assistance.
THE PUMP IS NOISY	Pump malfunction.	Call for Technical Assistance.



If the problem cannot be resolved, turn the machine off and call for Technical Assistance. Do not attempt any sort of repairs.

